

STANDING SEAM PROFILING MACHINES

Roof and Facade





Operating in the standing seam metal roof machinery and equipment sector for more than 18 years, REIS Standing Seam Technologies has adopted continuous development, quality and customer satisfaction as its principle. Offering the best quality and complementary products of the standing seam roofing sector, which produces with the latest technology, REIS is the leader in the Turkish market.

REIS Standing Seam Technologies is a well-known brand in the world by exporting its products to more than 30 countries. It provides its customers with timely sales and service professionally.

REIS, which has adopted the mission of creating technological and economic differences throughout its entire development, has become a brand that has completed the production and tests of its products from the design stage with its R&D studies and brought them together with standing seam roof appliers. REIS Standing Seam Technologies offers non-competitive savings to its customers.

With the awareness that the only thing that does not change in the world is change, REIS will continue to be an exemplary brand for new generations in the future due to its mission.





STANDING SEAM TECHNOLOGIES



Perform your metal roof applications in a quality-oriented manner by having one of the REIS STANDING SEAM MACHINES.

All machine models are designed to provide Standing seam roofers maximum mobility at low cost.

Machines are produced with the highest precision on CNC Processing Machines.

As REIS STANDING SEAM TECHNOLOGIES, we always support our customers with spare parts on stock, from production to assemble, from sales to technical service.

Every manufactured "R-PRO" Standing Seam Machine goes through delicate tests.



It has CE Certificate and EU Attestation of Compliance Certificate

You can work with different kind of metals and produce high quality Standing seam roof panels.

You can produce Standing seam profiles using painted steel, aluminum, titanium zinc, copper or stainless steel.

Perfect Standing seam profile production with 25 mm seam height is achieved in a single pass from coil or sheet.

Standing seam profiles can also be produced from conical sheets.
The minimum axial dimension 80 mm with single-sided seam production



WHY R-PRO?



- Maximum Performance machines with low cost
- Alternative models suitable for all standing seam projects and different budgets
- Professional service from production to assembly, from sales to technical service
- Machines that exceed expectations
- Fast delivery time
- 2 Years of Warranty
- CE Certificate
- ISO 9001:2015
- ISO 12100:2010
- ISO 13857:2019
- EN 60204-1:2018
- 2006/42/EC
- 2014/35/EU



MODEL R-PRO 25

STANDING SEAM PROFILING MACHINE

The basic model "R-PRO 25" is a very light and compact Standing seam roof profiling machine that can easily be carried to anywhere.

Metal roof profiling machine that you can work with trouble-free for years with its easy use, high performance, efficiency and durability.

High precision Standing seam panel production is possible without any length limit.

Remote controller, lockable wheels, detachable infeed arms, reverse function and emergency stop features are included.

Chrome-plated rollers provide excellent build quality and longer lifespan.

Digital Control Unit (Optional Equipment)



VIDEO



Please scan the QR code.

Product Website



MODEL R-PRO 25 PLUS

STANDING SEAM PROFILING MACHINE

If you wish to have a qualified Standing seam machine with a low budget and also want to have many features in one roof profiling machine; the right choice is the “R-PRO 25 PLUS” Model.

The most important features of the “R-PRO 25 PLUS” Standing Seam Machine are: It has a **Digital Control Unit**, **Ribbing Attachment Equipment** and a **Cutting Device** at the exit of the profiling machine.

Chrome-plated rollers and ribbing attachments provide excellent build quality and longer lifespan.

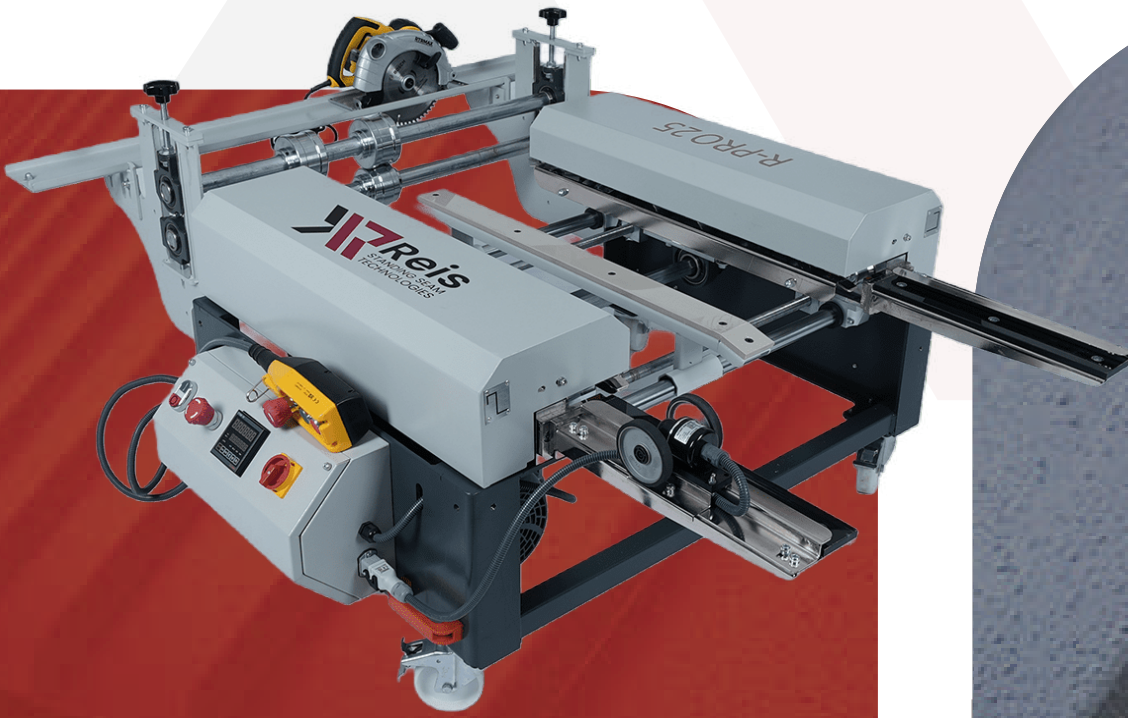

VIDEO



Please scan the QR code.

Product Website



MODEL R-PRO DUO

STANDING SEAM PROFILING MACHINE

“R-PRO DUO” standing seam profiling machine has a cutting device at the ahead of the machine. Cutting is done at the ahead of profiling shaping in a perfect way.

When the desired length is reached, the material is cut at the entrance as standing seam production is carried out without any waste.

Remote controller, digital control unit, ribbing attachments and cutting device equipments are included.

Chrome-plated rollers and ribbing attachments provide excellent build quality and longer lifespan.

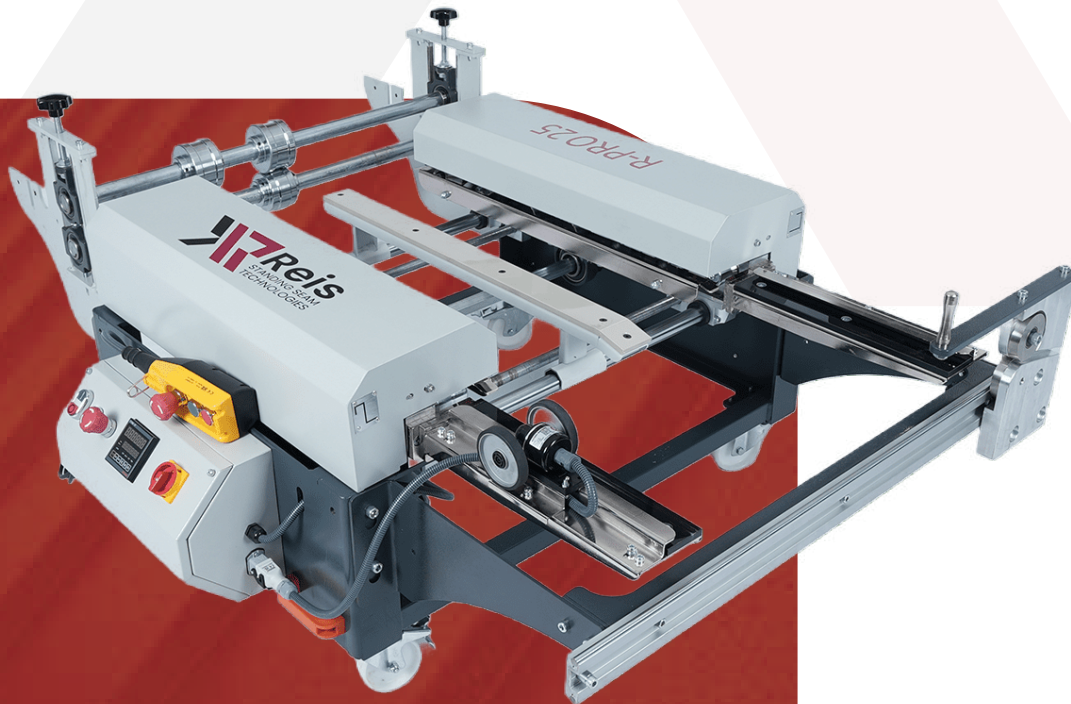

VIDEO



Please scan the QR code.

Product Website



MODEL R-PRO MAX

STANDING SEAM PROFILING MACHINE

“R-PRO MAX” Standing Seam Machine from REIS STANDING SEAM TECHNOLOGIES, known for its Innovation and Superior Quality in the Architectural Metal Industry.

“R-PRO MAX “ is a portable Standing seam machine, ideal for both workshop and jobsite operations, with a guillotine shear system at the machine exit.

Guillotine shear makes clean cut in a single move without damaging the form of the 25 mm seam height of the panel. Does not damage the surface of painted or patinated materials.

“R-PRO MAX” Standing Seam Profiling Machine is a fully equipped model with a **manual guillotine shear, digital encoder unit and ribbing attachment equipment.**

Chrome-plated rollers and ribbing attachments provide excellent build quality and longer lifespan.

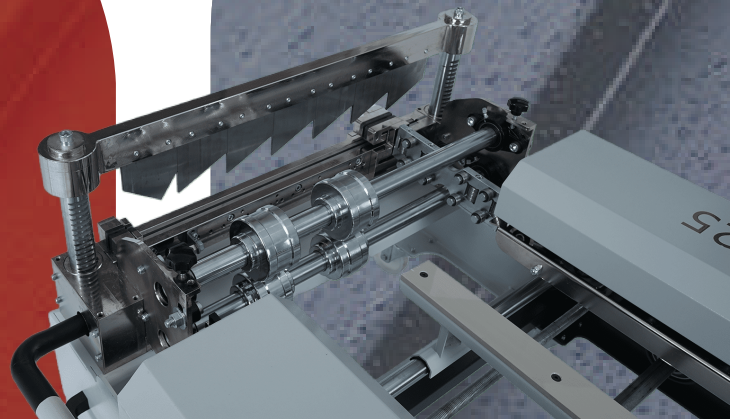

VIDEO



Please scan the QR code.

Product Website





TECHNICAL FEATURES



MODEL R-PRO 25

Operating Voltage	220 V / 50 Hz / 1 ph.
Drive Power	1 x 1.1 kw
Operating Speed	9 m/min
Forming Stages	7 stations
Shortest Panel Length	500 mm
Infeed Width	250 – 700 mm
Dimensions (LxWxH)	900 mm x 1300 mm x 750 mm (wheeled)
Axial Dimension	170 mm – 620 mm (depending on material)
Weight	190 kgs



Processable Metals	Titanium Zinc up to 0,80 mm
	Copper up to 0,80 mm
	Aluminium up to 0,80 mm
	Steel (galvanized and coated) up to 0,70 mm
	Stainless Steel up to 0,50 mm

Included Features

Remote controller, Lockable wheels, Detachable infeed arms, Reverse function and emergency stop, CE and ISO Certificates

Optional Equipment

Digital Control Unit

MODEL R-PRO 25 PLUS

Operating Voltage	220 V / 50 Hz / 1 ph.
Drive Power	1 x 1.1 kw
Operating Speed	9 m/min
Forming Stages	7 stations
Shortest Panel Length	500 mm
Infeed Width	250 – 700 mm
Dimensions (LxWxH)	1300 mm x 1300 mm x 750 mm (wheeled)
Axial Dimension	170 mm – 620 mm (depending on material)
Weight	245 kgs



Processable Metals	Titanium Zinc up to 0,80 mm
	Copper up to 0,80 mm
	Aluminium up to 0,80 mm
	Steel (galvanized and coated) up to 0,70 mm
	Stainless Steel up to 0,50 mm

Included Features

Remote controller, Lockable wheels, Detachable infeed arms, Ribbing attachments, Circular saw, Digital encoder, Reverse function and emergency stop, CE and ISO Certificates



TECHNICAL FEATURES



MODEL R-PRO DUO

Operating Voltage	220 V / 50 Hz / 1 ph.
Drive Power	1 x 1.1 kw
Operating Speed	9 m/min
Forming Stages	7 stations
Shortest Panel Length	500 mm
Infeed Width	250 – 700 mm
Dimensions (LxWxH)	1300 mm x 1300 mm x 750 mm (wheeled)
Axial Dimension	170 mm – 620 mm (depending on material)
Weight	250 kgs

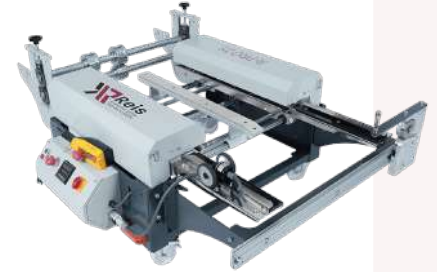

Processable Metals

- Titanium Zinc up to 0,80 mm
- Copper up to 0,80 mm
- Aluminium up to 0,80 mm
- Steel (galvanized and coated) up to 0,70 mm
- Stainless Steel up to 0,50 mm

Included Features

Remote controller, Lockable wheels, Detachable infeed arms, Ribbing attachments, Sliding shear system
Digital encoder, Reverse function and emergency stop, CE and ISO Certificates

MODEL R-PRO MAX

Operating Voltage	220 V / 50 Hz / 1 ph.
Drive Power	1 x 1.1 kw
Operating Speed	9 m/min
Forming Stages	7 stations
Shortest Panel Length	500 mm
Infeed Width	250 – 700 mm
Dimensions (LxWxH)	1300 mm x 1300 mm x 750 mm (wheeled)
Axial Dimension	170 mm – 620 mm (depending on material)
Weight	300 kgs



Processable Metals

- Titanium Zinc up to 0,80 mm
- Copper up to 0,80 mm
- Aluminium up to 0,80 mm
- Steel (galvanized and coated) up to 0,70 mm
- Stainless Steel up to 0,50 mm

Included Features

Remote controller, Lockable wheels, Detachable infeed arms, Ribbing attachments,, Digital encoder,
Manual guillotine shear, Reverse function and emergency stop, CE and ISO Certificates



STANDING SEAM PROFILING MACHINES

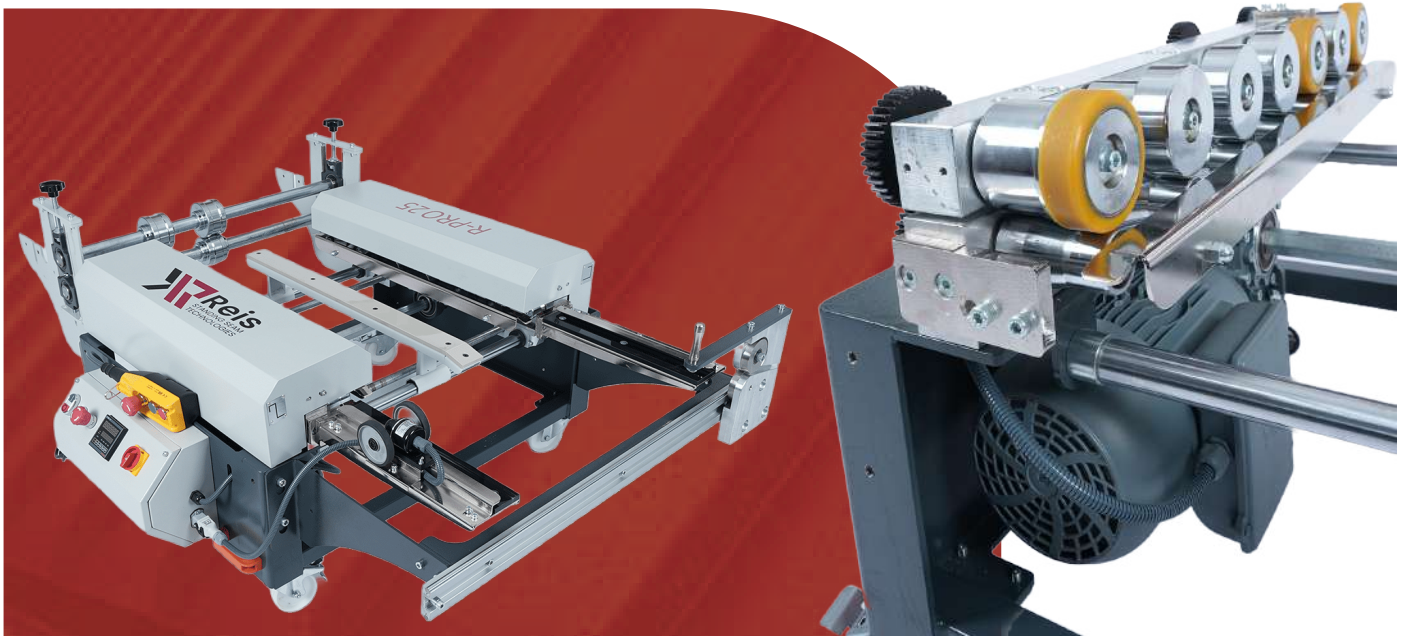



STANDING SEAM PROFILING MACHINES

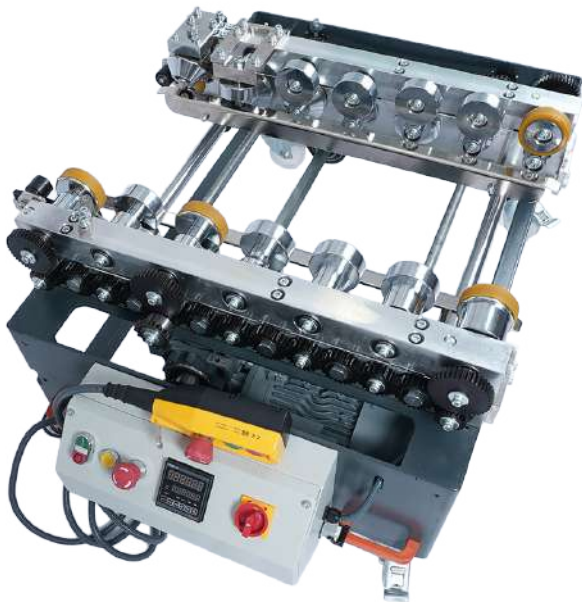
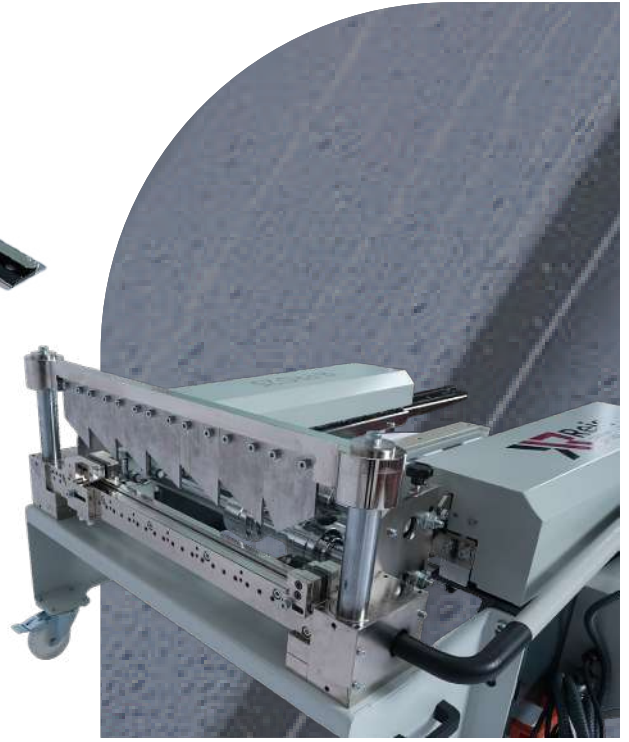

POSSIBLE FORMS

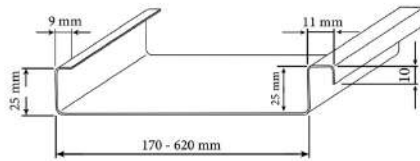

Standart Standing Seam 25
Axial Width between 170-620 mm

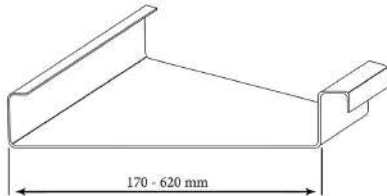

Angled Standing Seam 25
Axial Width between 170-620 mm

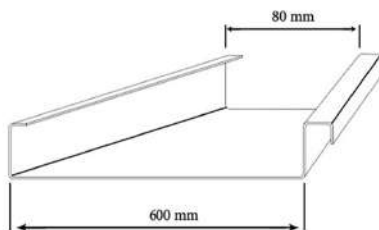

Conical Standing Seam 25
Min and max measures are given

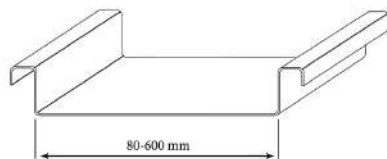

Standing Seam 25 - Both Sides Female
Input Width between 80-600 mm
Forming is done in 2 operations.

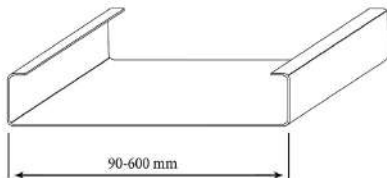

Standing Seam 25 - Both Sides Male
Input Width between 90-600 mm
Forming is done in 2 operations.

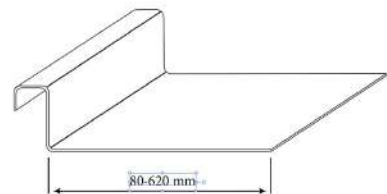

Standing Seam 25 - One side Female
Input Width between 80-620 mm

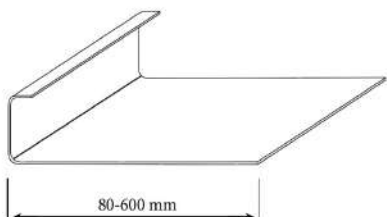

Standing Seam 25 - One side Male
Input Width between 80-600 mm

R1500 DECOILER

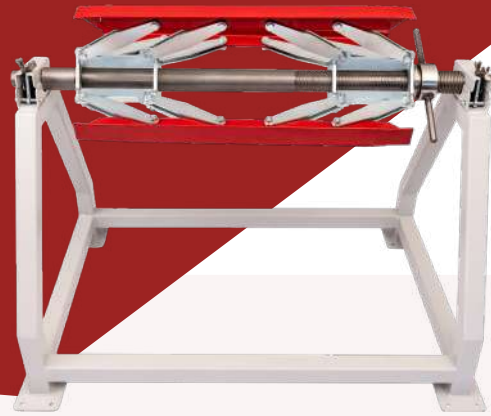

Economical manual decoiler compatible with standing seam machines, roll-form and industrial sheet metal working machines used for different purposes.

The R-1500 decoiler model has a maximum lifting of 1500 kg and a working width of 800 mm.

Thanks to its light weight, it can be easily carried anywhere.

It has an inner diameter in the range of 30-60 cm. It can be narrowed and expanded with the adjustment lever.

Since it is internally compressed, the roll will never shift to the right or left.

QUALITY and TRUST REIS STANDING SEAM TECHNOLOGIES

- It goes through delicate tests.
- It is manufactured from special profiles, has a robust chassis and is long-lasting.
- It has a very solid chassis.

TECHNICAL FEATURES

Coil Lifting Capacity	1500 kg Max.
<small>***Different capacities can be produced optionally</small>	
Coil Working Width	800 mm Max.
<small>***Different capacities can be produced optionally</small>	
Inner Diameter Width	Adjustable between 300 mm – 600 mm
Weight	70 kg
L x W x H	790 mm x 116 mm x 850 mm



SS - SINGLE HAND LOCK SEAMER 90°



TECHNICAL FEATURES

Backenbreite	220 mm
Jaw Depth	50 mm
Total Length	390 mm
Weight	2000 gr.

It closes the standing seam panels at a 90° angle in a single operation with fast and easy way. Working width 220 mm.

It is the hand seamer used for locking the panels produced by "R-PRO 25" Standing seam profiling machine.

Single lock standing seam metal roof system is designed to prevent water from entering the panels.

Standing seam panels cover each other when installed on the roof, so there is no space in between.

DS - DOUBLE HAND LOCK SEAMER 180°



TECHNICAL FEATURES

Backenbreite	220 mm
Jaw Depth	50 mm
Total Length	480 mm
Weight	2500 gr.

It closes the standing seam panels at a 90° angle in a single operation with fast and easy way. Working width 220 mm.

It is the hand seamer used for locking the panels produced by "R-PRO 25" Standing seam profiling machine.

Single lock standing seam metal roof system is designed to prevent water from entering the panels.

Standing seam panels cover each other when installed on the roof, so there is no space in between.

EC - EAVES CLOSING JAWS



TECHNICAL FEATURES

Backenbreite	220 mm
Jaw Depth	60 mm
Total Length	400 mm
Weight	2100 gr.

Best hand seamer for closing the eaves on standing seam application with a fast and easy way.

By the help of this hand seamer tool, you guarantee water tightness at the eaves end. Working width 220 mm

Standing seam metal roof system is designed to prevent water from entering the panels.

Standing seam panels cover each other when installed on the roof, so there is no space in between.



Reis

STANDING SEAM
TECHNOLOGIES

Phone: +90 (212) 320 20 69
Whatsapp: +90 (212) 320 20 69
E-mail: info@reiskenet.com.tr
Address: Konaklar Mah. Selvili Sk. No:1/2
4. Levent - Beşiktaş / İstanbul 34330
Website: www.reiskenet.com.tr



Social Media